

Course: Intro to Transportation

Unit of Instruction: Internal Combustion Engines

1. Major Course Skills/Units of Study:

Transportation Technology
Internal Combustion Engine

2. Situation or Problem:

Given teacher information from lecture, internet sites and powerpoint documents and materials supplied, students will understand and demonstrate knowledge of the systems of steam, 4 cycle, and 2 cycle engines.

3. Project Description, Design Brief or Purpose:

The teacher will give information by lecture and powerpoint documentation. The students will demonstrate knowledge and application of the systems used in steam, 4 cycle, and 2 cycle engines.

Students will list the systems and parts of these systems on a word document and write definitions to these terms. They will also look up these systems on the internet and copy pictures and animation site locations so they can look at the system at any time to study.

Students will clean, take apart, identify the parts, and reassemble small 4 cycle engines using appropriate tools and safety equipment.

This assignment gives the beginning student the essentials in learning the basic systems of these power sources, cycles, fuel system, electrical system, cooling system, and computer applications.

4. Performance Specifications, Guidelines or Rules:

Complete the word vocabulary document, clean, take apart, and identify the parts of a 4 cycle engine, and reassemble small 4 cycle engines using appropriate tools and safety equipment.

Student will correct documents and reassemble until accurately meeting instructor specifications.

5. Specific Project Core Competencies:

- **Technical Skills – Computer Application –Word, Basic Tool Use.**
- **Academic Skills – Measuring, Ratios, Ohms law, Surface Area, Physics Principles.**
- **Employment-Related Skills – Automotive Repair and Computer Applications.**
- **Career Transition Skills – Measuring Skills, Computer Application Skills, Presentation Skills, Basic System Understanding.**

Transportation Technologies

Outline based on OSPI Model Curriculum Framework

ITEA Standard 18: Transportation Technologies Standards & Competencies

Standards DW-TT 1: Develop an understanding of The Designed World to select and use transportation technologies.

- DW-TT1.1 Transportation plays a vital role in the operation of other technologies, such as manufacturing, construction, communications, health and safety, and agriculture.
- DW-TT1.2 Intermodalism is the use of different modes of transportation, such as highways, railways, and waterways as part of an interconnected system that can move people and goods easily from one mode to another.
- DW-TT1.3 Transportation services and methods have led to a population that is regularly on the move.
- DW-TT1.4 The design of transportation systems depends on many processes and innovative techniques.

DW-TT1.5 All Transportation Technology programs need to include appropriate tool skills, health and safety, the manipulation of related materials, and the development of appropriate products (physically, digitally or virtually).

Standard DW-TT 2: Investigate career opportunities in the transportation industry, explore the impact of transportation on our society and identify a variety of transportation technologies.

DW-TT2.1 Identify occupations related to the transportation industry.

DW-TT2.2 State the differences between past and present methods of transportation technologies.

DW-TT2.3 Identify a variety of systems, methods and materials for building transportation technologies.

DW-TT2.4 Learn and use safe work habits and techniques.

Standard DW-TT 3: Understand the role/use of energy in transportation.

DW-TT3.1 Understand and define *transportation* and *power*.

DW-TT3.2 Identify sources of energy.

DW-TT3.3 Demonstrate an understanding of energy conversion.

DW-TT3.4 Demonstrate an understanding of mechanical systems.

DW-TT3.5 Demonstrate an understanding of electrical systems.

DW-TT3.6 Demonstrate an understanding of fluid power systems.

Standard DW-TT 4: Investigate the modes of transportation.

DW-TT4.1 Demonstrate an understanding of transportation in the world of aviation systems.

DW-TT4.2 Demonstrate an understanding of transportation in the world of aerospace systems.

DW-TT4.3 Demonstrate an understanding of transportation in the world of land systems.

DW-TT4.4 Demonstrate an understanding of transportation in the world of marine systems.

DW-TT4.5 Demonstrate an understanding of intermodal transportation systems.

Standard DW-TT 5: Investigate the nature and meaning of *vehicular systems*.

DW-TT5.1 Demonstrate an understanding of propulsion of a vehicle.

DW-TT5.2 Demonstrate an understanding of guidance of a vehicle.

DW-TT5.3 Demonstrate an understanding of control of a vehicle.

DW-TT5.4 Demonstrate an understanding of suspension of a vehicle.

DW-TT5.5 Demonstrate an understanding of structure of a vehicle.

DW-TT5.6 Demonstrate an understanding of support of a vehicle.

DW-TT5.7 Explore transportation technologies of the future.

ITEA Standard 16: Energy & Power Technologies Standards & Competencies

Standard DW-EPT 1: Develop an understanding of The Designed World to select and use energy and power technologies.

DW-EPT1.1 Energy cannot be created nor destroyed; however, it can be converted from one form to another.

DW-EPT1.2 Energy can be grouped into major forms: thermal, radiant, electrical, mechanical, chemical, nuclear, and others.

DW-EPT1.3 It is impossible to build an engine to perform work that does not exhaust thermal energy to the surroundings.

DW-EPT1.4 Energy resources can be renewable or nonrenewable.

DW-EPT1.5 Power systems must have a source of energy, a process, and loads.

DW-EPT1.6 All Energy and Power Technology Education programs need to include appropriate tool skills, health and safety, the manipulation of related materials, and the development of appropriate products (physically, digitally or virtually).

Standard DW-EPT 2: Investigate career opportunities in the energy industry, explore the impact of energy on our society, and identify a variety of energy technologies.

DW-EPT2.1 Identify occupations related to the energy industry.

- DW-EPT2.2 State the differences between past and present methods of energy technologies.
- DW-EPT2.3 Identify a variety of systems, methods and materials for building energy technologies.
- DW-EPT2.4 Learn and use safe work habits and techniques.

Standard DW-EPT 3: Identify and understand conversion and converters.

- DW-EPT3.1 Identify and explain energy conversion using mechanical converters
- DW-EPT3.2 Identify and explain energy conversion using thermal converters
- DW-EPT3.3 Identify and explain energy conversion using chemical converters
- DW-EPT3.4 Identify and explain energy conversion using solar converters
- DW-EPT3.5 Identify and explain energy conversion using fluid converters

Standard DW-EPT 4: Identify and understand energy and power transmission.

- DW-EPT4.1 Identify and explain mechanical transmission of energy and power.
- DW-EPT4.2 Identify and explain fluid transmission of energy and power.
- DW-EPT4.3 Identify and explain electrical transmission of energy and power.

Standard DW-EPT 5: Identify and understand energy resources.

- DW-EPT5.1 Understand renewable and nonrenewable energy resources.
- DW-EPT5.2 Demonstrate energy conservation practice.

6. Assessment:

Students will present their Word documents with 100% accuracy. Students will fix document until completed and the presentation will meet industrial and teacher standard.

Students will clean, take apart, and identify the parts of a 4 cycle engine, and reassemble small 4 cycle engines using appropriate tools and safety equipment. Student will correct documents and reassemble until accurately meeting instructor specifications.

Students will pass the Vocabulary Exam with at least 60% accuracy.

7. Supplies/Materials and Community Resources:

Word Computer programs, old small engines, tool kits, specialty portable tools.

Name
Transportation 3
Date

4 Cycle Engine

Intake-

Compression-

Power-

Exhaust-

<http://science.howstuffworks.com/engine4.htm>

2 Cycle Engine

Power, Intake and Exhaust-

Intake & Compression-

<http://science.howstuffworks.com/two-stroke2.htm>

Carburetor system

Intake

Venturi-

Bowl-

Float-

Needle valve-

Idle adjust-screw needle valve -

Throttle adjust -

Choke/ butter fly valve-

Throttle Butterfly-



<http://auto.howstuffworks.com/question377.htm>

Electrical Systems

Ways to create electricity

A. Chemical-

B. Magnet -

Parts & how they work

Magnet-

Coil-

Primary coil -

Secondary coil -

Points -

Condenser -

Spark Plug -

Sensor -

When does this happen-

<http://auto.howstuffworks.com/ignition-system.htm>

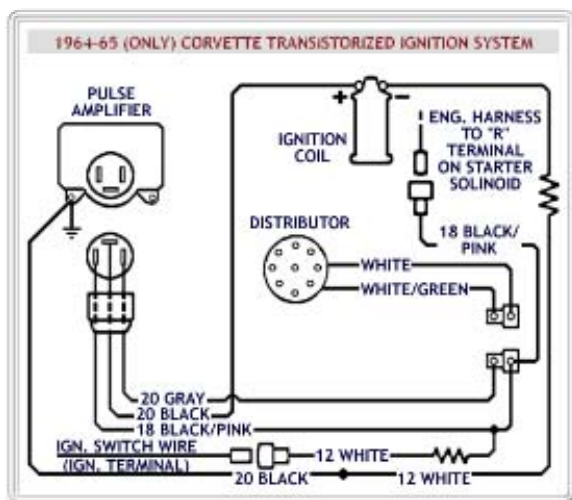

Cooling system

Air Cooling

Shrouds-

Fans-

Fins-

Fluid Cooling

Radiator-

Water Jacket-

Thermostat -

Radiator -

Water Pump-

Fan-

Electrical -

Manual -

<http://auto.howstuffworks.com/cooling-system.htm>

